

Diamond D R I V E

Thanks for purchasing a Diamond Drive!

We hope you have as much fun playing guitar through this pedal as we did designing and testing it. Our goal is to provide a new twist on classic drive tone, and to make it just plain fun to play.

Remember to protect your hearing and wear appropriate hearing protection when playing loud...

Design Features

True bypass signal path

Dual stage overdrive / lead circuit

Premium audio components, including 2% polypropylene capacitors and 1% metal film resistors.

Warmth control – replaces the traditional fixed frequency cut/boost circuit with a variable high-frequency cutoff filter coupled with variable low-frequency gain.

Switchable Diamond Drive signature raw compression or conventional overdrive compression.

Battery or standard negative tip 9V DC adapter operation

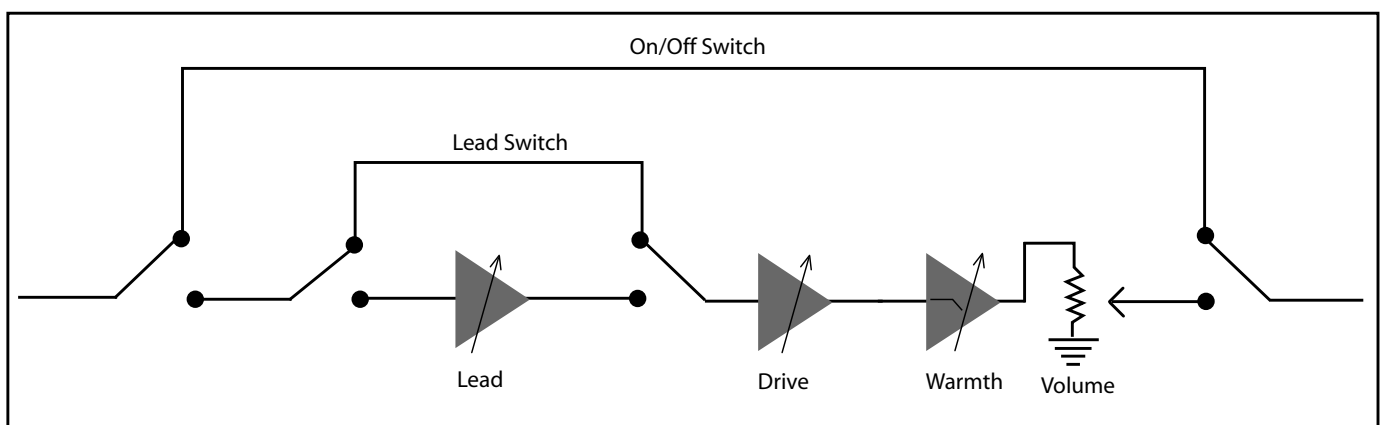

Controls

Drive

This controls the basic overdrive level. Backing it off gives a mild and controlled overdrive sound, while opening it up gives more of a straight ahead distortion. Pickup output levels will also impact the drive level – humbuckers generally will more easily push the drive and your amp into distortion. It's important to note that the drive circuit and its control remain part of the signal path even when switched to lead mode, with overall distortion controlled by a combination of the drive and lead controls (and the warmth control too!).

Warmth

The tone control, as mentioned previously, is not a typical fixed frequency cut/boost circuit. The warmth circuit acts as a low-pass filter coupled with gain boost as the cut off frequency drops. This certainly adds a different flavor to the feel of the overdrive than traditional overdrive circuits. Moving the dial clockwise moves the filter cutoff point lower, darkening the signal, but at the same time increasing gain, potentially adding more harmonics depending on the signal and level.

Volume

This adjusts the overall output volume of the box. Once the relative levels of drive and lead are set, this control can be used to adjust overall clean vs. effect levels.

Lead

This sets the output level of the lead circuit and determines the level of extra gain provided in addition to the basic drive circuit. In many ways the lead circuit acts like the high gain stage in a cascaded triode channel switching tube amp. Here, the lead circuit provides a stage of additional transistor amplification before the signal reaches the core op-amp based drive stage. With the lead set to 12 noon or less, the effect is essentially a louder, more tonally aggressive version of the basic crunch tone of the drive. Setting the lead past 3 PM pushes the pedal into a unique combination of liquid sustain with a tinge of fuzz.

There are many different interesting combinations of drive, lead and warmth settings. You'll get great tone with everything set to 12 o'clock, but it's worth taking some time to explore the different settings and interplay between the controls.

Switches

On/Off

This switches the pedal between bypass and in-circuit operation. A green LED indicates that the pedal is on. The overdrive mode that the pedal switches to when turned on is dependent on the current position of the lead switch.

Lead

This switches the additional transistor gain circuit in and out of operation. As with the on/off switch, this switch features true bypass operation with the lead circuit completely removed from the signal path when off. Operation is indicated with the red LED on. It is important to note that even with the overall on/off foot switch turned off (but an instrument plugged in), the lead switch can still be preset to the desired mode of operation, with the red LED still indicating status of the lead circuit. This allows a guitarist to visually set the pedal to drive or lead modes prior to bringing it into the signal path.

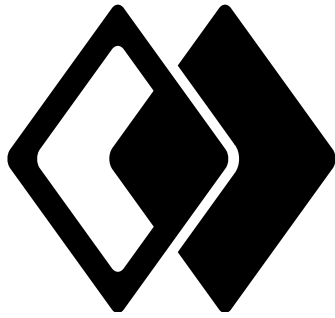

Diamond

DRIVE

Compression

A small unlabeled switch on the front facing edge, past the Warmth and Volume controls, gives two settings of compression and sustain. The up position of the switch is a more traditional over-drive setting, with lots of smooth compression, while the down position has a more raw sound. We've found the up position sounds best for Marshall-style mid-gain amplifiers, but the best thing to do is experiment to find the best setting for your particular guitar/amp setup.

Powering

Changing the battery

Changing the standard 9V battery first requires the removal of the four back corner screws of the pedal. The battery clip is attached to the inside of the back plate - gently pull the back plate off so as not to strain the connecting wires between the battery clip and main circuit board. After replacing the battery, carefully place any slack in the connecting wires into the box cavity, and replace the back plate with the four screws, taking care not to pinch the connecting wires.

Using a 9V adapter

Any standard 9V DC negative pin AC adapter for effect pedals can be used to power the Diamond Drive. The insertion of the AC adapter plug automatically removes the internal battery from the circuit.

Warranty

Diamond Pedals carry a full five year warranty on registered products - make sure to send us your warranty card! The warranty is simple - if you have a problem, call us, send us the pedal if necessary, and we'll make it right.

Suggested Settings

The pedal has been designed to give great tone with all four controls at the 12 noon position. However, we also have a few favorite settings that we've become pretty fond of, so we've stuck them in below for you to try out. All of our settings use the jumper in the factory pre-set DD custom setting.

The General

This is a great general overdrive setting. When you just want the "right" sound. Vary the drive between 4 and full on 10 depending on the song. Stomp on the lead when you need that extra boost during a song.



Furball

What can we say? Just overdrive everything. Sounds great with pickups in the neck position, run through something bright like an AC30's brilliant channel



Angry Young Man

Try this with a single coil in the bridge position, but through something darker like an AC30's normal channel. Great crunch sound. Then take it to another level by switching on Lead.



Gravy

Try this also with a single coil in the bridge position. With light picking, you get amazing and articulate bell-like tones, dig in, and you get some great but mild overdrive. (Lead switch is off)



Bifurcator

This one works great with either the bridge or neck pickup. Definitely a heavier overdrive bordering on flat out distortion.

